

EXCELLENT SUPPORTING PERFORMANCE

The Genie® Super Tower™ is the industry standard for theatrical productions and entertainment events. It telescopes lighting, sound systems and scenery weighing up to 800 lbs (363 kg) and can lift to heights up to 26 ft .5 in (7.94 m). And the standard flat black anodized finish blends in perfectly backstage, making it virtually invisible to audiences. It's also compact and portable for easy transport and storage.

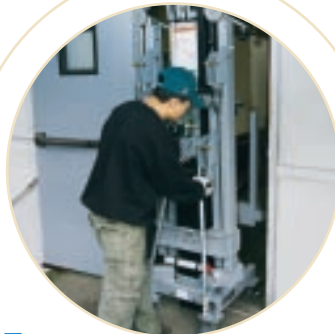

EASY TRANSPORT AND STORAGE

The compact stowed position makes the Super Tower™ easy to move through doors and load on trucks with no bulky base to get in the way. Stowed dimensions are 22 in (56 cm) by 25.25 in (64 cm).

OPTIONS AND ACCESSORIES

TWO-SPEED WINCH OPTION allows you to shift gears during operation.

LOAD PLATFORM fits over standard forks with no tools required to handle heavy or odd-shaped objects.

FORK EXTENSIONS insert onto standard forks for an additional 25 in (64 cm) of length.

QUICK, SIMPLE SETUP

Just install the outriggers and set the leveling jacks.

SUPER TOWER™ MODELS AVAILABLE

ST™-20 | ST™-25

**The ideal choice for lifting and supporting
lighting/sound systems and stage scenery while blending in backstage.**

Features

EASILY CONFIGURED TO MEET YOUR NEEDS

FORK OPTIONS

- Load platform
- Fork extensions

POWER OPTIONS

- One-speed winch
- Two-speed winch

BASE

- Standard base

CASTER

- Standard casters

OPTIONS & ACCESSORIES

PRODUCTIVITY

- Load platform
- Fork extensions

POWER

- Two-speed winch

STANDARD FEATURES

MEASUREMENTS

ST™-20

- 21 ft 2.5 in (6.46 m) working height
- Up to 800 lb (363 kg) load capacity

ST™-25

- 26 ft .5 in (7.94 m) working height
- Up to 650 lb (295 kg) load capacity

PRODUCTIVITY

- Use as a single unit, or two or more can be used together to support trusses
- Flat black anodized finish is nearly invisible to audience
- Portable and compact design
- Lightweight, durable aluminum construction
- Single-door access
- Easy set-up with no tools required
- Durable steel forks
- Hand winch locks in place when handle is released
- Easy to transport—no bulky base
- Hold-down mechanism secures carriage during transport

POWER

- One-speed winch
- Reversible winch handle for easy storage



Specifications

| MODELS | ST™-20 | | ST™-25 | |
|---------------------------------------|--------------------|-----------------|--------------------|-----------------|
| MEASUREMENTS | US | Metric | US | Metric |
| A Height - stowed | 6 ft 6.75 in | 2.2 m | 6 ft 6.75 in | 2.2 m |
| B Length - stowed | 2 ft 1.25 in | .64 m | 2 ft 1.25 in | .64 m |
| C Width - stowed | 1 ft 10 in | .56 m | 1 ft 10 in | .56 m |
| D Load height minimum | 6 in | .15 m | 6 in | .15 m |
| E Ground clearance - center | 2 in | .05 m | 2 in | .05 m |
| Working height - forks up | 21 ft 2.5 in | 6.46 m | 26 ft .5 in | 7.94 m |
| - forks down | 19 ft 6 in | 5.94 m | 24 ft 4 in | 7.42 m |
| PRODUCTIVITY | | | | |
| Load capacity - at 18 in load center | 800 lbs | 363 kg | 650 lbs | 295 kg |
| Length - adjustable forks | 27.5 in | .70 m | 27.5 in | .70 m |
| Width - adjustable forks | 11.5–30 in | .29–.76 m | 11.5–30 in | .29–.76 m |
| Fork extensions detached each (l/w/d) | 30/2/3 in; 4.5 lbs | 76/5/8 cm; 2 kg | 30/2/3 in; 4.5 lbs | 76/5/8 cm; 2 kg |
| Fork extensions attached each (l/w/d) | 25/2/3 in; 4.5 lbs | 64/5/8 cm; 2 kg | 25/2/3 in; 4.5 lbs | 64/5/8 cm; 2 kg |
| Weight - adjustable forks | 52.5 lbs | 24 kg | 52.5 lbs | 24 kg |
| Outrigger footprint | 73.5 x 79.5 in | 1.87 x 2.02 m | 73.5 x 79.5 in | 1.87 x 2.02 m |
| Casters | standard casters | | standard casters | |
| POWER | | | | |
| One-speed winch - average cranks | 8.5 cranks/ft | 28 cranks/m | 8.5 cranks/ft | 28 cranks/m |
| WEIGHT* | | | | |
| | 507 lbs | 230 kg | 555 lbs | 252 kg |

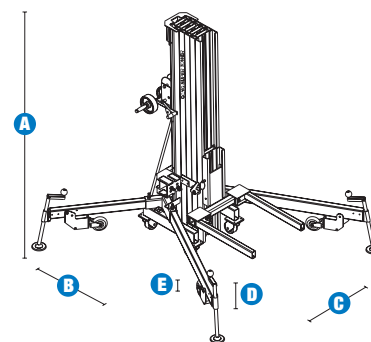

* Weight will vary depending on options and/or country standards.

Genie United States

18340 NE 76th Street
P.O. Box 97030
Redmond, Washington 98073-9730
Telephone **+1 (425) 881-1800**
Toll Free in USA/Canada **+1 (800) 536-1800**
Fax +1 (425) 883-3475

Genie Europe

Millennium House
Brunel House
Newark NG24 2DE
UK
Telephone **+44 (0)1476 584333**
Fax +44 (0)1476 584334
Email: infoeurope@genieind.com

Distributed By:

Effective Date: January, 2008. Product specifications and prices are subject to change without notice or obligation. The photographs and/or drawings in this document are for illustrative purposes only. Refer to the appropriate Operator's Manual for instructions on the proper use of this equipment. Failure to follow the appropriate Operator's Manual when using our equipment or to otherwise act irresponsibly may result in serious injury or death. The only warranty applicable to our equipment is the standard written warranty applicable to the particular product and sale and we make no other warranty, express or implied. Products and services listed may be trademarks, service marks or trade-names of Terex Corporation, Genie Industries, Inc. and/or their subsidiaries in the U.S.A. and many other countries and all rights are reserved. Terex® is a Registered Trademark of Terex Corporation in the U.S.A. and many other countries. Genie® is a Registered Trademark of Genie Industries, Inc. in the U.S.A. and many other countries. Genie is a Terex Company. © 2008 Terex Corporation.